

Instruction manual



THS 1900
1 x 60W RMS
CLASS D



The installation of this product must be made by a qualified professional.



www.taramps.com.br

Index

- 01** • Introduction
 - Presentation
- 02** • Important recommendations
 - Audio source
 - Package content
- 03** • Knowing your equipment
 - Front panel
- 04** • Knowing your equipment
 - Front panel
 - Rear panel
- 05** • Remote Control Function
- 06** • Bluetooth
 - Bluetooth use Example
- 07** • Example of using RCA connection
 - Connect Control use example
- 08** • Connection examples - Ceiling speaker
 - Term of warranty
 - Technical assistance
- 09** • Technical features

Introduction

Congratulations on purchasing a Taramps product.

Developed in a modern laboratory, with highest technology and highly qualified professionals.

This manual explains all the resources, operations and guidelines for resolving questions that may arise in your installation. Take a time to read it carefully and ensure the proper installation and use of all the benefits that this product can offer.

In case of doubt even after reading this manual, please contact our technical support at the number **+55 18 3266 4050** or our website **www.taramps.com.br**.

Presentation

The TARAMPS THS 1900 is a Receiver developed with high technology to integrate different environments. Compact and powerful it can be used in several applications providing quality sound.

Application examples:

- Environment sound for stores, shops and clinics. It also allows, through the microphone input, that warnings are transmitted via the sound system.
- In your leisure area, gourmet space, country house, etc. Including various audio input options, such as Bluetooth, AUX and USB, it allows the audio sources to be easily changed giving the user flexibility in choosing the preferred audio.

The equipment is automatic bivolt and can be connected to any power plug between 90 and 240V. It has a switching power supply that is more efficient in the consumption of electricity. To turn the device on and off, use the ON/OFF switch located on the front panel. Keep turned off when not in use.

If you are not going to use the product for a long time, we recommend that you disconnect from the power plug.

Important recommendations

- The THS 1900 must be installed in a firm and ventilated place, away from heat and humidity places. Avoid locations with direct sunlight.
- Do not block the ventilation holes on the top and rear.
- Avoid falls and impacts.
- Carefully observe the polarity and impedance of the loudspeakers.
- Use cables according to the distance between the THS 1900 and the loudspeakers.

The table below shows the recommended gauges according to the distances:

Until 20m	cables with a gauge larger than or equal to	1 mm²
Until 40m	cables with a gauge larger than or equal to	1,5 mm²
Until 70m	cables with a gauge larger than or equal to	2,5 mm²
Until 100m	cables with a gauge larger than or equal to	4 mm²

- In case of unwanted noise make sure that the cables and connections are in good condition.

Audio source

The TARAMPS THS 1900 has the following audio inputs:

1. USB: Flash drive input *
2. MICRO SD CARD *
3. AUX (front): P2 standard auxiliary input
4. AUX1 and AUX2: RCA standard auxiliary inputs
5. BLUETOOTH
6. FM radio
7. Microphone input (standard P10)

* The connected device must contain music in MP3 format to be identified by the equipment. Maximum supported size: 64GB.

 We advise you to always have a good antivirus, so there are no problems with the Flash Drive or micro SD card when connecting to the product. Infected devices may cause undesirable effects to the THS 1900, such as: Slow music reading and general failures.

Do not use the USB input to connect to the computer or to recharge other devices that have batteries.

Package content

- 01 Multi Channel Receiver THS 1900



- 01 Remote Control



- 01 AC Adapter 12V - 03 Amperes
- 01 Antena Bluetooth



Illustrative image

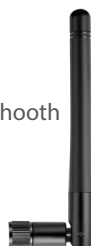

Knowing your equipment

Front Panel

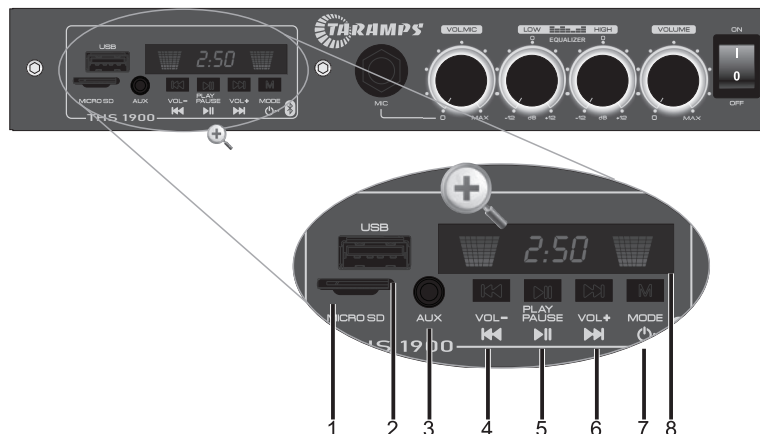

1 - MICRO SD: Micro SD memory card input.  (The card must be positioned as the image shows, with the terminals facing up).

2 - USB: Flash Drive input.

3 - Aux. (P2 Connector): Receives audio signal from the P2 output of your phone, tablet, MP3, computer, among others. Use good quality cable to avoid unwanted noise.

4 - Track - / Volume -:

Short Touch: Rewind the music tracks in the USB/SD/BLUETOOTH. Reduce 0.1MHz of the frequency.

Long Touch: Reduce the volume in all sources options. Automatic search to previous stations.

5 - Play / Pause:

Short Touch: Pause or start the music on USB / SD / BLUETOOTH. Advances next saved memory position of FM stations.

Mute for AUXILIARY option.

Long Touch: Searches for FM stations and saves them in memory.

6 - Track + / Volume +:

Short Touch: Forward the music tracks in the USB/SD/ BLUETOOTH. Increase 0.1MHz of the frequency.

Long Touch: Increase the volume in all sources options. Automatic search to next stations.

7 - Mode / ON/OFF:

Short Touch: Changes the source options, such as: USB / SD / AUXILIARY / BLUETOOTH / FM.

Long Touch: Turns the player on or off, leaving only the microphone input active.

8 - LED Display - Remote control IR sensor: For better communication between the remote control and the device, point the control at this point on the display.

Knowing your equipment

Front Panel (sequence)



9 - MIC: P10 input for microphone.

Recommendations: The microphone signal has low amplitude, so inappropriate use can cause unwanted noise. Use good quality cable and connectors, avoid tangling the cable and avoid being close to the speakers when in use, as this can cause feedback.

10 -MIC VOL: Microphone volume adjustment. If you do not use the microphone, it is recommended to leave the volume at minimum. The MIC input is mixed with the other audio sources. To leave only the microphone active, turn off the player using the MODE key.

11 -EQUALIZATION: 2 band audio equalizer adjust.

LOW: Bass frequencies

HIGH: High frequencies.

12 -VOL: Adjusts the output volume.

13 - ON/OFF KEY: Turns the device on and off.

When turned on, the panel lights up blue.

Rear Panel

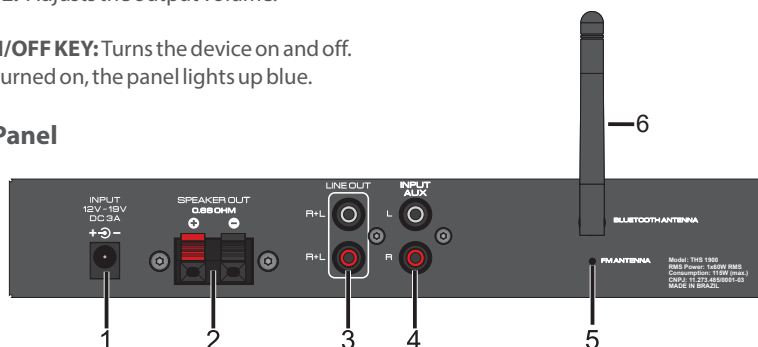

1 - POWER CABLE: Connect the original source that comes with the product.

Attention: It is not recommended to use sources with voltage and amperage outside those specified.

2 - SPEAKER OUT: To connect the loudspeakers. Follow the indicated polarity and the recommended minimum impedance of 0.66 ohms.

3 - LINE OUT: The LINE OUT output allows you to send the audio signal (not amplified) to other equipment, such as a THS 3600, an active amplifier or subwoofer. This signal goes through the equipment's equalization settings (LOW and HIGH).

4 - AUX INPUT: L and R (RCA) input works in parallel with the front AUX input (connector P2).











5 - FM ANTENNA: Indoor wire antenna for FM radio reception. Position the wire antenna in order to achieve the best FM reception.

6 - BLUETOOTH ANTENNA: External antenna for better reception of the Bluetooth range.

Remote control functions

The THS 1900 has a compact remote control, so you can remotely control the device with practicality.



-  **ON / OFF:** Press this key to turn the player on or off.
-  **MODE:** Switch the audio source (USB, BLUETOOTH, SD, AUXILIARY, FM).
-  **MUTE:** Player only.
-  **PLAY / PAUSE:** Pause or start the music to USB / SD / BLUETOOTH.
FM: Short Press: Advances next saved memory location of FM stations.
Long Press: Searches for FM stations and saves them in memory.
-  **TRACK - / FOLDER - / FM-:**
Short Press: Previous 0.1MHz of the frequency. Previous track
Long Press: Previous folder. Automatic search to the previous station.
-  **TRACK + / FOLDER + / FM+:**
Short Press: Next 0.1MHz of the frequency. Next track
Long Press: Automatic search to the next station. Next folder
-  **EQUALIZATION:** Pop / Rock / Jazz / Country / Normal.
Do not work in auxiliary mode.
FM: Short Press Return to the saved memory position of FM stations.
-  **VOL-:** Volume down
-  **VOL+:** Volume up
-  **REPEAT:** Repeat /play MP3 options
-  **USB / SDCARD / FM-MEMO:**
Switch mode between USB / SD Card. Searches for FM stations and saves them in memory.
- NUMERIC KEYBOARD:** FM: Long Press saves FM stations.

Bluetooth

When selecting the Bluetooth function (identified with "bt" on the display), the THS 1900 waits for a Bluetooth connection. Search for the device called "TARAMPS" using your phone, tablet, PC or other and match it.

- To connect to a new device, disconnect the current one and make the new Bluetooth pairing. Bluetooth specification: class II with a 30m maximum range and may vary according to the environment (such as walls) and the connected device.



For other devices the connection system is similar (consult manufacturer's manual)

Bluetooth use example

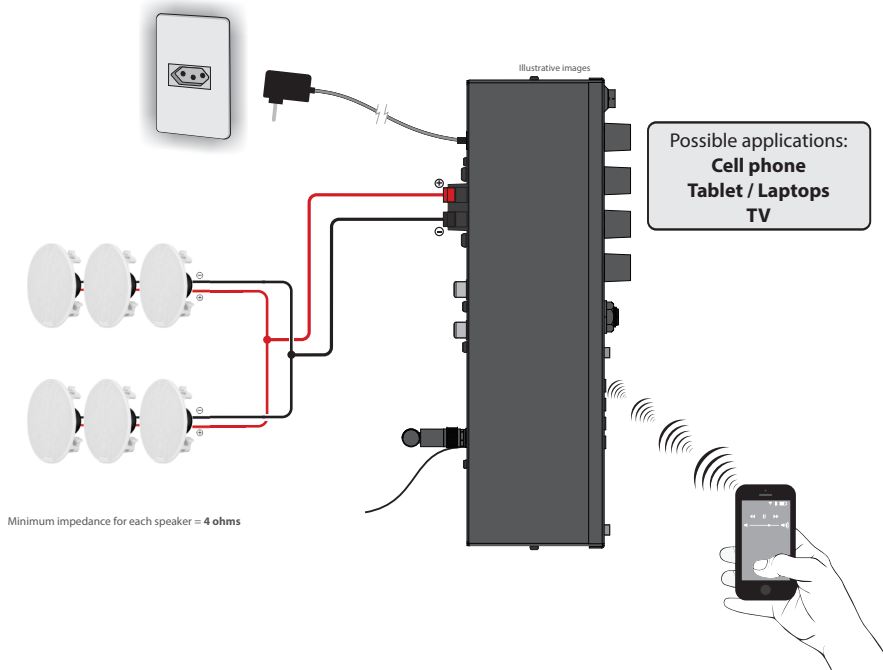

Some TVs have an audio output system via Bluetooth. If your TV has this feature, it's possible to transmit the audio to the THS 1900. Consult your TV manufacturer's manual.

Example of using an RCA connection

Select the AUX function on the "SOURCE" key.

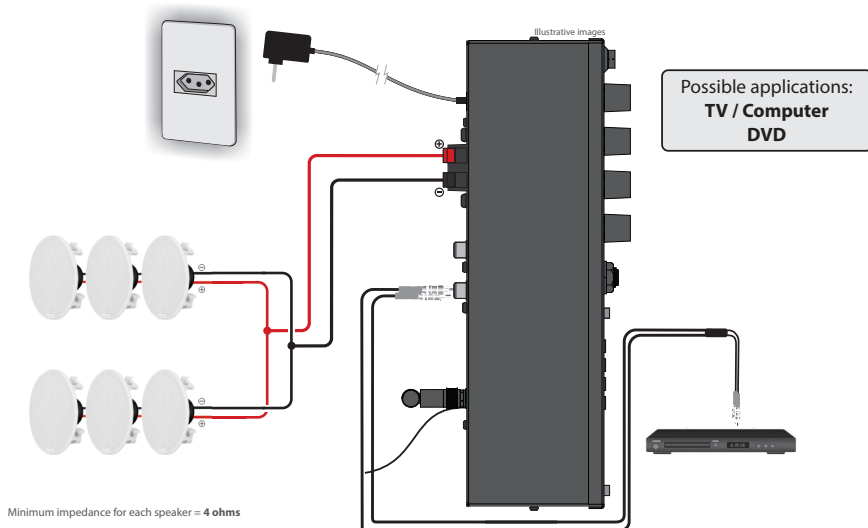

Connect control use example (Long range transmitter)

The THS 1900 is compatible with the CONNECT CONTROL, TARAMPS long range remote control which allows you to control your sound over wide distances and without the need to point the control at the device. The THS 1900 does not lose the functionality of the USB port, as the connect control allows a Flash Drive to be plugged into its USB port.

* For more details on the CONNECT CONTROL TARAMPS functionalities consult in its manual on the website.

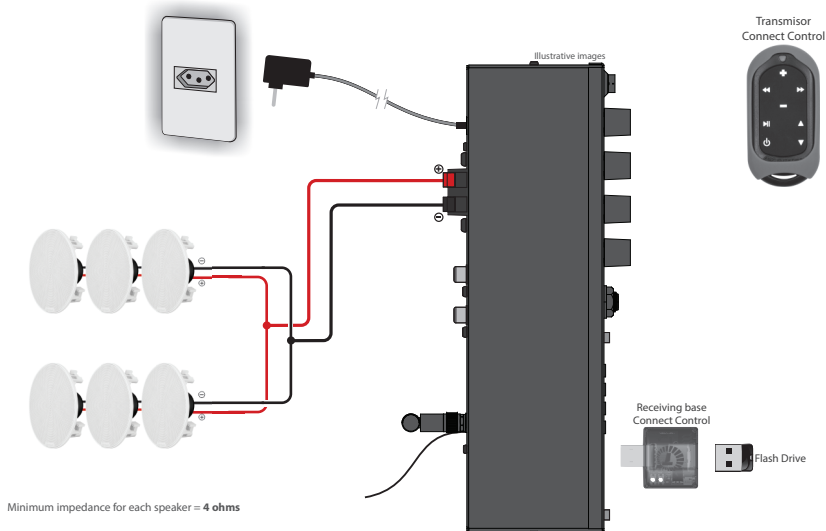

NOTE: Connect Control Taramps is sold separately.

Technical features

TARAMPS THS 1900:_____	Receiver Mono Channel Class D
Number of Channels:_____	01
RMS Power:_____	60W
Minimum output impedance_____	0.66 Ohm
AUX input Sensitivity:_____	400 mV
Sensibilidade do MIC:_____	10 mV
AUX Input impedance:_____	10KOhm
Impedância de entrada do MIC:_____	2.2KOhms
Frequency response (equalizers at 0 dB):_____	20 Hz ~ 20 KHz (-3 dB)
Typical 2-way equalizer performance:	
Low (bass):_____	±15 dB - 100 Hz
High:_____	±15 dB - 5 KHz
Power Supply:_____	100 ~ 240V AC
Consumption in Stand by:_____	1.4W
Maximum consumption:_____	115W
Protection System:_____	Output protection against short and overheating
Ratio signal/noise:_____	>70 dB
FM frequencies:_____	87.5 MHz ~ 108 MHz
Dimensions:_____	250 x 47 x 118mm (9.84" x 1.85" x 4.65")
Weight of product:_____	0.42 Kg (0.92 lb)
Weight of AC Adapter:_____	0.35 Kg (0.77 lb)

The values mentioned are typical and may change due to the tolerance of components or the manufacturing process.

For more information or questions visit our website or contact TARAMPS support.



Taramps reserves the right to modify the contents of this manual without prior notice and not to apply the modifications to units previously produced.



+55 18 3266-4050

Manufactured by:
TARAMPS ELECTRONICS LTDA
TAX ID: 11.273.485/0001-03
Highway: Julio Budisk, SN, KM 30
Alfredo Marcondes - SP
Made in Brazil
www.taramps.com.br