

# T 500 SW

## SPEAKER 8" - 4 OR 8 OHMS

The **T 500SW** is a subwoofer that was designed to suit the most varied types of sound systems, be it residential or car audio, and can be used in residential boxes, Home Theaters, 3-way boxes and etc, due to its frequency response, from 35hz to 5000hz, as well as structured to handle 250 watts RMS. Available at 4 ohms, this product has a sensitivity of 90.755 dB, aligned with a great linearity of response and quality throughout its operating range. Live a new experience listening to your playlist with a fidelity that will amaze your ears.



### MECHANICAL PARAMETERS

RMS POWER	250 W
MUSICAL PROGRAM POWER	500 W
NOMINAL IMPEDANCE	4 ohms / 8 ohms
RESISTANCE (RE)	4.4 ohms / 6.5 ohms VCC
FREQUENCY RESPONSE	37Hz à 5.000Hz
RESONANCE FREQUENCY	44.844 Hz
NO (EFFICIENCY REFERENCE)	0.748%
SENSITIVITY (@ 1W, 1m)-Free-Air	90.755 dB
DIAPHRAGM MASS (MMD)	20.581 g
TOTAL MASS (MMS)	22.412 g
BL PRODUCT	7.983 TM
MECHANICAL Q (Qms)	6.347
ELECTRIC Q (Qes)	0.436
TOTAL Q (Qts)	0.408
COMPLIANCE (CMS)	562.020u M/N
EQUIVALENT VOLUME (VAS)	37.380 L
Le @ 1 kHz (coil inductance at 1kHz)	1.8450 mH
EFFECTIVE CONE AREA (SD)	0.0216 Sq.m
CONE EXCURSION WITHOUT DISTORTION (X MAX)	+/- 5.4 mm
FLOW DENSITY IN THE GAP	7.800 GAUSS

*Thielle-Small parameters are obtained after applying a sinusoidal level of 50hz for a period of 30 minutes. A tolerance of +/- 15% on the specified values is allowed.*

### PRODUCT DIMENSIONS

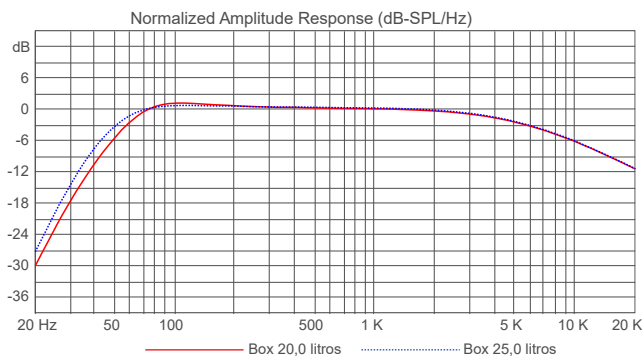
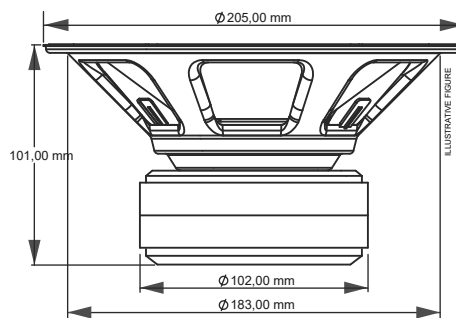

### MECHANICAL PARAMETERS

NOMINAL DIAMETER	8 Inches
FERRITE MEASURES	2 to 102 X 43 X 14mm
COIL DIAMETER	1 1/4 Inches
COIL HEIGHT	13 mm
COIL WIRE MATERIAL	CCAW
COIL WIRE SECTION	Round
COIL SHAPE	*Kapton
GAP HEIGHT	6,35 mm
HOUSING MATERIAL	Steel
FERRITE MATERIAL	Barium
WEIGHT	2.1 Kg
VOLUME OCCUPIED ON THE CABINET	0.991 Liters

\* Kapton trademark registered by DUPONT

### CABINETS SUGGESTION

MODEL	VOLUME	DUCTS	DUCTS	DUCTS	SINTONY	(H.P.F)	ATTENUATON (ACTIVE)
	LITERS	QUANT.	DIAM.	DEPTH			
VENTED BOX	20	01	3"(POL)	210 mm	50,0 Hz	40 Hz	- 24 dB/ Oitava
	25	01	3"(POL)	200 mm	45,0 Hz	35 Hz	- 24 dB/ Oitava

NOTE: Features, specifications and appearance are subject to change without notice.

