



MB 1K8



Carefully designed and produced to provide high definition and sound pressure from the mid-bass to the mid-high, in addition to the most varied types of applications in sound systems, it has an outstanding result in the "horned" speaker boxes, making your sound system more intelligible and clear in its operating range. Its construction has an excellent harmony between all the components involved in this project, so that the desired result goes beyond expectations, amplifying your listening experience with high quality sound.

ELECTRICAL PARAMETERS

RMS POWER	900 W
MUSICAL PROGRAM POWER	1.800 W
NOMINAL IMPEDANCE	6 Ohms
RESISTANCE	4,25 ohms/VCC
NO (EFFICIENCY REFERENCE)	2,00%
DIAPHRAGM MASS (MMD)	68,938 g
TOTAL MASS (MMS)	76,054 g
BL PRODUCT	17.613 TM
MECHANICAL Q (Qms)	6,750
ELECTRIC Q (Qes)	0,431
TOTAL Q (Qts)	0,405
COMPLIANCE (CMS)	76,769u M/N
EQUIVALENT VOLUME (VAS)	31,204 L
SENSITIVITY (@ 1W, 1 m)-Free-Air	95,028 dB
FREQUENCY RESPONSE	65 to 4.850 Hz
RESONANCE FREQUENCY	65,867 Hz
Le @ 10 kHz (coil inductance at 10 kHz)	0,337 mH
EFFECTIVE CONE AREA (SD)	0,0535 Sq.m
CONE EXCURSION WITHOUT DISTORTION (X MAX)	- + 8,5 mm
FLOW DENSITY IN THE GAP	13.550 GAUSS

Thiele-Small parameters are obtained after applying a sinusoidal level of 50hz for a period of 30 minutes. A tolerance of + - 15% on the specified values is allowed.

MECHANICAL PARAMETERS

NOMINAL DIAMETER	12 Inches
FERRITE MEASURES	220 x 25 mm
COIL DIAMETER	4 Inches
COIL HEIGHT	21 mm
COIL WIRE MATERIAL	CCAW
COIL WIRE SECTION	Round
COIL SHAPE	*Kapton®
GAP HEIGHT	8 mm
HOUSING MATERIAL	Aluminum
FERRITE MATERIAL	Barium
WEIGHT	1,61 Kg
VOLUME OCCUPIED ON THE CABINET	3,98 Liters

*Kapton® Marca registrada pela DUPONT

CABINETS SUGGESTION

MODEL	VOLUME	DUCTS	DUCTS	DUCTS	SYNTONY	(H.P.F)	ATTENUATION
	LITERS	QUANT.	DIAM.	DEPTH			
VENTED BOX	40	03	4"(POL)	175 mm	80 Hz	70 Hz	-24 dB/ Octave
	45	03	4"(POL)	290 mm	65 Hz	60 Hz	-24 dB/ Octave
	45	03	4"(POL)	195 mm	73 Hz	70 Hz	-24 dB/ Octave

SUGGESTIVE MEASURES

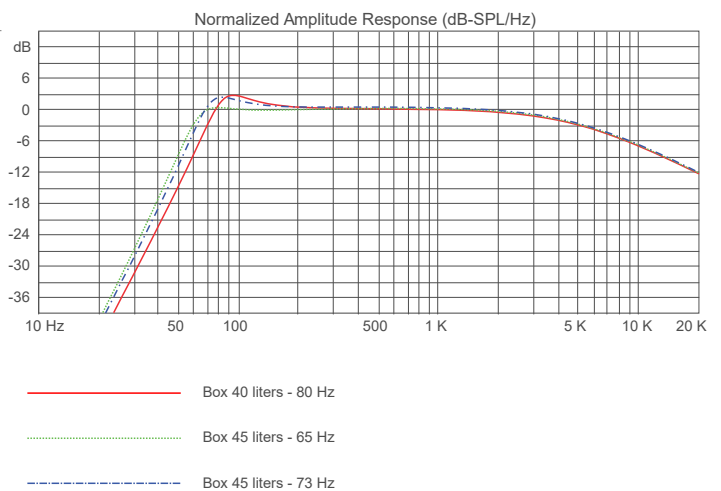
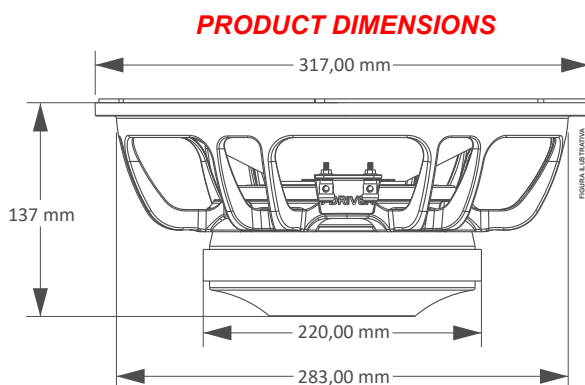

www.taramps.com.br

Rod. Julio Budisk SP 501 s/n, - Compl. KM 30-A/SP ZIP:19.180-000 Phone Number +55 (18) 3266-4050 National Registry(CNPJ): 23.372.795/0001-64

Note: Features, specifications and aesthetics are subject to change without notice.

WARRANTY TERM

When all our products are produced, they undergo rigorous evaluations, in each construction process until they are packaged, however, if any type of abnormality is detected, when opening the package, it must be sent to one of our authorized service stations, or directly to the factory, if there is not an authorized technician in your region. **Each and every product must undergo a technical evaluation so that the defect is identified and proven.**

The product has a warranty of 15 (fifteen) months after the issuance of the invoice, with the legal warranty of 90 days, provided for in article 26, item II, of law No. 8078/90 (Brazilian consumer protection code).

Warranty Conditions:

The product must be installed correctly, by a specialized professional, as well as respecting the product characteristics.

The customer **will NOT** have the warranty when:

- Exceed the period of 15 (fifteen) months.
- Damages incurred are caused by; transport or handling accident, or humidity.
- Defects caused by improper installation.
- Malfunctions in product parts (torn cone/dust cap, bent or broken speaker housing).
- Coils burned out by excessive power or extreme distortion conditions, causing heating above 240°.

Warranty Coverage:

- Taramps guarantees its products against any defect in material or manufacturing process, provided that, at the discretion of its authorized technicians, it is found to be defective under normal conditions of use.
- **The PRODUCT must contain the original label, on which its serial number is inserted.**
- To use the warranty, the customer must present the invoice and the warranty term, both of which must contain the serial number on the product label.

Transport

Only products that fall under the terms of warranty coverage will have their transportation expenses covered, otherwise, the expense will be at the customer's expense.

WARRANTY CERTIFICATE

NAME: _____

ADDRESS: _____

CITY: _____ ZIP: _____

STATE: _____ PHONE: _____

DEALER: _____

ADDRESS: _____

CITY: _____ ZIP: _____

STATE: _____ PHONE: _____

INVOICE NUMBER