



SL 1K6



The SL 1K6, was designed to reproduce the sub bass and bass, in car sound systems and professional performance systems (bands, concerts, bars, churches, outdoor systems, theaters, cinemas and etc).

We invite you to dive into a sound experience, where low frequencies are harmonized with great fidelity, through velvety bass and clean timbres.

ELECTRIC PARAMETERS

RMS POWER	800 W
MUSICAL PROGRAM POWER	1.600 W
NOMINAL IMPEDANCE	4 or 8 Ohms
RESISTANCE (RE)	3,0 / 5,9 ohms/VCC
NO (EFFICIENCY REFERENCE)	1,423%
DIAPHRAGM MASS (MMD)	184,936 g
TOTAL MASS (MMS)	209,229 g
BL PRODUCT	14.635 TM
MECHANICAL Q (Qms)	14,248
ELECTRIC Q (Qes)	0,638
TOTAL Q (Qts)	0,611
COMPLIANCE (CMS)	87,826u M/N
EQUIVALENT VOLUME (VAS)	183,512 L
SENSITIVITY (@ 1W, 1 m)-Free-Air	93,552 dB
FREQUENCY RESPONSE	28 to 1300 Hz
RESONANCE FREQUENCY	37,128 Hz
EFFECTIVE CONE AREA (SD)	0,1213 Sq.m
CONE EXCURSION WITHOUT DISTORTION (X MAX)	- + 11,5 mm
FLOW DENSITY IN THE GAP	8.470 GAUSS

Thiele-Small parameters are obtained after applying a sinusoidal level of 50hz for a period of 30 minutes. A tolerance of + - 15% on the specified values is allowed.

MECHANICAL PARAMETERS

NOMINAL DIAMETER	18 Inches
FERRITE MEASURES	200 x 25 mm
COIL DIAMETER	4 Inches
COIL HEIGHT	29 mm
COIL WIRE MATERIAL	Copper
COIL WIRE SECTION	Round
COIL SHAPE	Fiber
GAP HEIGHT	14 mm
HOUSING MATERIAL	Aluminum
FERRITE MATERIAL	Barium
WEIGHT	12,3 Kg
VOLUME OCCUPIED ON THE CABINET	11,6 Liters

CABINET SUGGESTION

MODEL	VOLUME	DUCTS	DUCTS	DUCTS	SYNTONY	(H.P.F)	ATTENUATION (ACTIVE)
	LITERS	QUANT.	DIAM.	DEPTH			
VENTED BOX	125	04	4"(POL)	310,6 mm	44 Hz	40 Hz	- 24 dB/ Octave
	145	04	4"(POL)	324,6 mm	40 Hz	35 Hz	- 24 dB/ Octave
	180	04	4"(POL)	264,9 mm	38 Hz	35 Hz	- 24 dB/ Octave

SUGGESTIVE MEASURES

*For professional lines, it is mandatory to use a cotton or glass wool blanket

PRODUCT DIMENSIONS

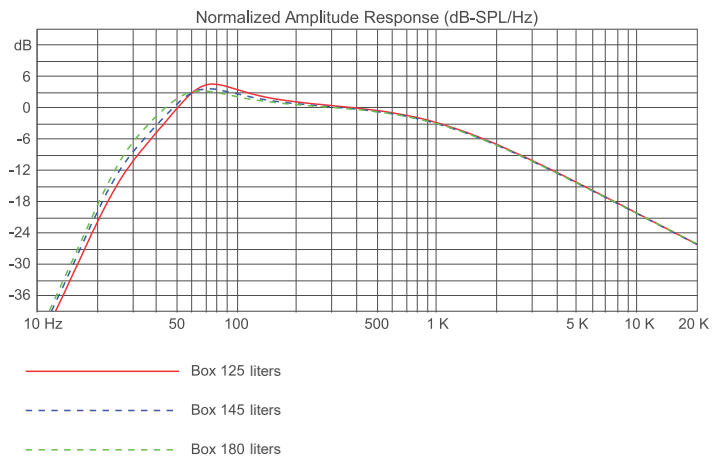
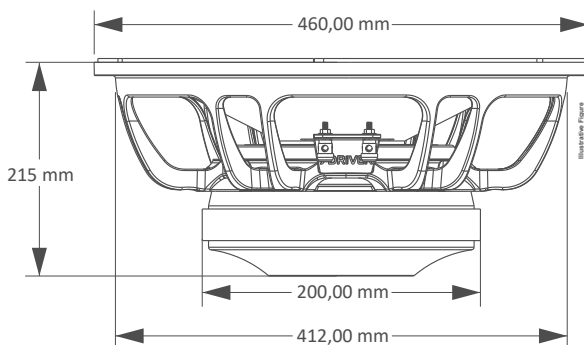

www.taramps.com.br

Rod. Julio Budisk SP 501 s/n, - Compl. KM 30-A/SP ZIP:19.180-000 Phone Number +55 (18) 3266-4050 National Registry(CNPJ): 23.372.795/0001-64

Note: Features, specifications and aesthetics are subject to change without notice.

WARRANTY TERM

When all our products are produced, they undergo rigorous evaluations, in each construction process until they are packaged, however, if any type of abnormality is detected, when opening the package, it must be sent to one of our authorized service stations, or directly to the factory, if there is not an authorized technician in your region. **Each and every product must undergo a technical evaluation so that the defect is identified and proven.**

The product has a warranty of 15 (fifteen) months after the issuance of the invoice, with the legal warranty of 90 days, provided for in article 26, item II, of law No. 8078/90 (Brazilian consumer protection code).

Warranty Conditions:

The product must be installed correctly, by a specialized professional, as well as respecting the product characteristics.

The customer **will NOT** have the warranty when:

- Exceed the period of 15 (fifteen) months.
- Damages incurred are caused by; transport or handling accident, or humidity.
- Defects caused by improper installation.
- Malfunctions in product parts (torn cone/dust cap, bent or broken speaker housing).
- Coils burned out by excessive power or extreme distortion conditions, causing heating above 240°.

Warranty Coverage:

- Taramps guarantees its products against any defect in material or manufacturing process, provided that, at the discretion of its authorized technicians, it is found to be defective under normal conditions of use.
- **The PRODUCT must contain the original label, on which its serial number is inserted.**
- To use the warranty, the customer must present the invoice and the warranty term, both of which must contain the serial number on the product label.

Transport

Only products that fall under the terms of warranty coverage will have their transportation expenses covered, otherwise, the expense will be at the customer's expense.

WARRANTY CERTIFICATE

NAME: _____

ADDRESS: _____

CITY: _____ ZIP: _____

STATE: _____ PHONE: _____

DEALER: _____

ADDRESS: _____

CITY: _____ ZIP: _____

STATE: _____ PHONE: _____

INVOICE NUMBER