



VL 250S



Designed for those who want a small sized product, for home or professional systems, as well as multipurpose boxes, advertisement cars, guitar amps and electric guitars, the 8-250s responds from 55Hz to 5,500Hz.

ELECTRICAL PARAMETERS

RMS POWER	125 W
MUSICAL PROGRAM POWER	250 W
NOMINAL IMPEDANCE	4 Ohms / 8 Ohms
RESISTANCE	3.1 / 5.8 VCC
NO (EFFICIENCY REFERENCE)	0.819%
SENSITIVITY (@ 1W, 1 m)-Free-Air	91.149 dB
DIAPHRAGM MASS (MMD)	15.429 g
TOTAL MASS (MMS)	17.227 g
BL PRODUCTO	7,589 TM
MECHANICAL Q (Qms)	4.372
ELECTRIC Q (Qes)	0.957
TOTAL Q (Qts)	0.785
COMPLIANCE (CMS)	204.277u M/N
EQUIVALENT VOLUME (VAS)	13,262 L
FREQUENCY RESPONSE	55Hz à 5.500Hz
RESONANCE FREQUENCY	84.841 Hz
Le @ 10 kHz (coil inductance at 10 kHz)	0.3511 mH
EFFECTIVE CONE AREA (SD)	0.0213 Sq.m
CONE EXCURSION WITHOUT DISTORTION (X MAX)	- + 4 mm
FLOW DENSITY IN THE GAP	10,800 GAUSS

Thiele-Small parameters are obtained after applying a sinusoidal level of 50 hz for a period of 30 minutes. A tolerance of + - 15% on the specified values is allowed.

PRODUCT DIMENSIONS

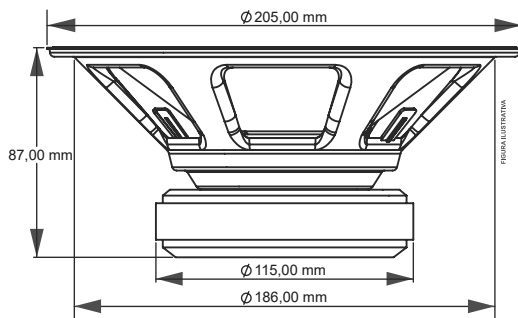

MECHANICAL PARAMETERS

NOMINAL DIAMETER	8 Inches
FERRITE MEASURES	115 X 56 X 16mm
COIL DIAMETER	1 1/4 Inches
COIL HEIGHT	13,5 mm
COIL WIRE MATERIAL	Copper
COIL WIRE SECTION	Round
COIL SHAPE	Fiber
GAP HEIGHT	6 mm
HOUSING MATERIAL	Steel
FERRITE MATERIAL	Barium
WEIGHT	1,86 Kg
VOLUME OCCUPIED ON THE CABINET	1,0 Liters

CABINET SUGGESTION

MODEL	VOLUME LITERS	DUCTS QUANT.	DUCTS DIÂM.	DUCTS PROF.	SYNTONY	(H.P.F)	ATTENUATION (ACTIVE)
VENTED BOX	22	02	2"(POL)	25 mm	81 Hz	76 Hz	- 24 dB/ Octave

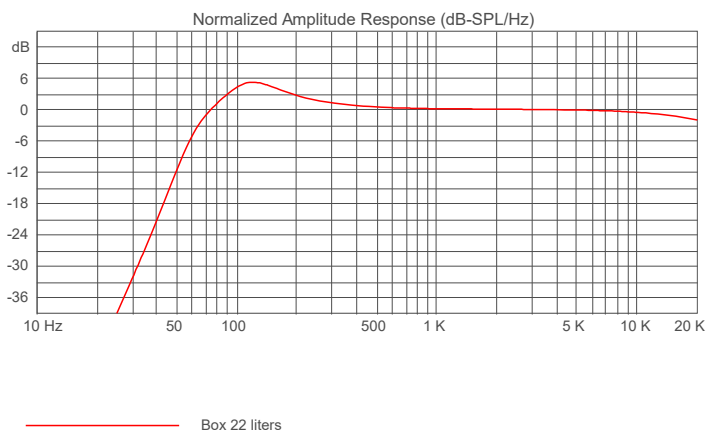

www.taramps.com.br

WARRANTY TERM

When all our products are produced, they undergo rigorous evaluations, in each construction process until they are packaged, however, if any type of abnormality is detected, when opening the package, it must be sent to one of our authorized service stations, or directly to the factory, if there is not an authorized technician in your region. **Each and every product must undergo a technical evaluation so that the defect is identified and proven.**

The product has a warranty of 15 (fifteen) months after the issuance of the invoice, with the legal warranty of 90 days, provided for in article 26, item II, of law No. 8078/90 (Brazilian consumer protection code).

Warranty Conditions:

The product must be installed correctly, by a specialized professional, as well as respecting the product characteristics.

The customer **will NOT** have the warranty when:

- Exceed the period of 15 (fifteen) months.
- Damages incurred are caused by; transport or handling accident, or humidity.
- Defects caused by improper installation.
- Malfunctions in product parts (torn cone/dust cap, bent or broken speaker housing).
- Coils burned out by excessive power or extreme distortion conditions, causing heating above 240°.

Warranty Coverage:

- Taramps guarantees its products against any defect in material or manufacturing process, provided that, at the discretion of its authorized technicians, it is found to be defective under normal conditions of use.
- **The PRODUCT must contain the original label, on which its serial number is inserted.**
- To use the warranty, the customer must present the invoice and the warranty term, both of which must contain the serial number on the product label.

Transport

Only products that fall under the terms of warranty coverage will have their transportation expenses covered, otherwise, the expense will be at the customer's expense.

WARRANTY CERTIFICATE

NAME: _____

ADDRESS: _____

CITY: _____ ZIP: _____

STATE: _____ PHONE: _____

DEALER: _____

ADDRESS: _____

CITY: _____ ZIP: _____

STATE: _____ PHONE: _____

INVOICE NUMBER