



# VL 300s



Designed for those who want a small sized product for systems at home or workplaces, multipurpose sound boxes, advertising cars, guitar and electric guitar amps. The VL 300s responds from 45Hz to 3.800Hz

## ELECTRICAL PARAMETERS

RMS POWER	150 W
MUSICAL PROGRAM POWER	300 W
NOMINAL IMPEDANCE	4 ohms / 8 ohms
RESISTÊNCIA	4.7 / 5.2 VCC
NO (EFFICIENCY REFERENCE)	1.081%
SENSITIVITY (@ 1W, 1 m)-Free-Air	92.356 dB
DIAPHRAGM MASS (MMD)	36.306 g
TOTAL MASS (MMS)	42.942 g
BL PRODUCTO	8.634 TM
MECHANICAL Q (Qms)	11.513
ELECTRIC Q (Qes)	1.118
TOTAL Q (Qts)	1.019
COMPLIANCE (CMS)	180.267u M/N
EQUIVALENT VOLUME (VAS)	66.766 L
FREQUENCY RESPONSE	45Hz à 4.000Hz
RESONANCE FREQUENCY	57.203 Hz
Le @ 10 kHz (coil inductance at 10 kHz)	0,5029 mH
EFFECTIVE CONE AREA (SD)	0,0510 Sq.m
CONE EXCURSION WITHOUT DISTORTION (X MAX)	- + 4 mm
FLOW DENSITY IN THE GAP	8.850 GAUSS

Thielle-Small parameters are obtained after applying a sinusoidal level of 50hz for a period of 30 minutes.

A tolerance of + - 15% on the specified values is allowed.

## PRODUCT DIMENSIONS

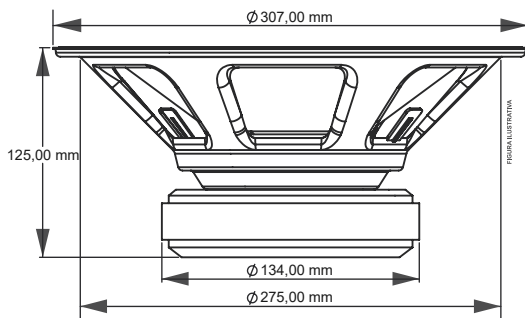

## MECHANICAL PARAMETERS

NOMINAL DIAMETER	12 Inches
FERRITE MEASURES	134 X 70 X 18mm
COIL DIAMETER	1 7/8 Inches
COIL HEIGHT	11,0 mm
COIL WIRE MATERIAL	Copper
COIL WIRE SECTION	Round
COIL SHAPE	Fiber
GAP HEIGHT	8 mm
HOUSING MATERIAL	Steel
FERRITE MATERIAL	Barium
WEIGHT	3,00 Kg
VOLUME OCCUPIED ON THE CABINET	2,8 Liters

## CABINET SUGGESTION

MODEL	VOLUME LITERS	DUCTS QUANT.	DUCTS DIAM.	DUCTS DEPTH	SYNTONY	(H.P.F)	ATTENUATION (ACTIVE)
VENTED BOX	49	02	3"(POL)	70 mm	61 Hz	58 Hz	- 24 dB/ Octave

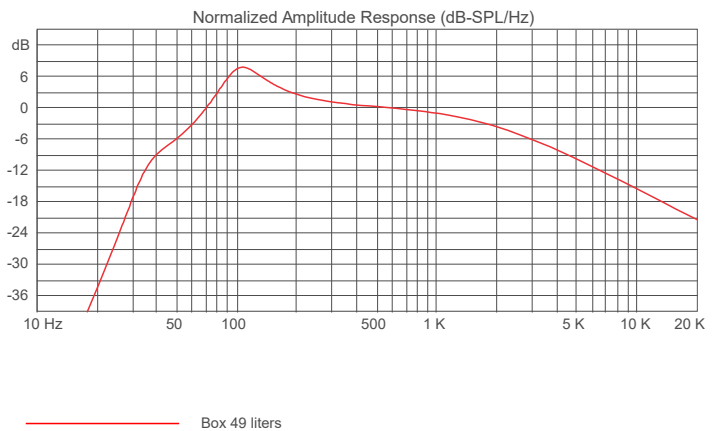

[www.taramps.com.br](http://www.taramps.com.br)

Rod. Julio Budisk SP 501 s/n, - Compl. KM 30-A/SP ZIP:19.180-000 Phone Number +55 (18) 3266-4050 National Registry(CNPJ): 23.372.795/0001-64

Note: Features, specifications and aesthetics are subject to change without notice.

## WARRANTY TERM

When all our products are produced, they undergo rigorous evaluations, in each construction process until they are packaged, however, if any type of abnormality is detected, when opening the package, it must be sent to one of our authorized service stations, or directly to the factory, if there is not an authorized technician in your region. **Each and every product must undergo a technical evaluation so that the defect is identified and proven.**

The product has a warranty of 15 (fifteen) months after the issuance of the invoice, with the legal warranty of 90 days, provided for in article 26, item II, of law No. 8078/90 (Brazilian consumer protection code).

### Warranty Conditions:

The product must be installed correctly, by a specialized professional, as well as respecting the product characteristics.

The customer **will NOT** have the warranty when:

- Exceed the period of 15 (fifteen) months.
- Damages incurred are caused by; transport or handling accident, or humidity.
- Defects caused by improper installation.
- Malfunctions in product parts (torn cone/dust cap, bent or broken speaker housing).
- Coils burned out by excessive power or extreme distortion conditions, causing heating above 240°.

### Warranty Coverage:

- Taramps guarantees its products against any defect in material or manufacturing process, provided that, at the discretion of its authorized technicians, it is found to be defective under normal conditions of use.
- **The PRODUCT must contain the original label, on which its serial number is inserted.**
- To use the warranty, the customer must present the invoice and the warranty term, both of which must contain the serial number on the product label.

### Transport

Only products that fall under the terms of warranty coverage will have their transportation expenses covered, otherwise, the expense will be at the customer's expense.

# WARRANTY CERTIFICATE

NAME: \_\_\_\_\_

ADDRESS: \_\_\_\_\_

CITY: \_\_\_\_\_ ZIP: \_\_\_\_\_

STATE: \_\_\_\_\_ PHONE: \_\_\_\_\_

DEALER: \_\_\_\_\_

ADDRESS: \_\_\_\_\_

CITY: \_\_\_\_\_ ZIP: \_\_\_\_\_

STATE: \_\_\_\_\_ PHONE: \_\_\_\_\_

INVOICE NUMBER