



# ML 520s



Enjoy bass and mid frequencies with intensity and definition, in one speaker that plays your favorite music with high quality and fidelity. The ML 520S will amaze you in the audio detail within its performance range. It can be used preferentially in sound trucks (electric trios).

## ELECTRICAL PARAMETERS

RMS POWER	520 W
MUSICAL PROGRAM POWE	1.040 W
NOMINAL IMPEDANCE	4 or 8 Ohms
RESISTANCE	2,8 / 5,9 ohms/VCC
NO (EFFICIENCY REFERENCE)	1,809%
DIAPHRAGM MASS (MMD)	30,344 g
TOTAL MASS (MMS)	34,490 g
BL PRODUCT	12.831 TM
MECHANICAL Q (Qms)	7,593
ELECTRIC Q (Qes)	0,584
TOTAL Q (Qts)	0,542
COMPLIANCE (CMS)	129,843u M/N
EQUIVALENT VOLUME (VAS)	25,687 L
SENSITIVITY (@ 1W, 1 m)-Free-Air	94,593 dB
FREQUENCY RESPONSE	60 to 4.500 Hz
RESONANCE FREQUENCY	75,2 Hz
EFFECTIVE CONE AREA (SD)	0,0373 Sq.m
CONE EXCURSION WITHOUT DISTORTION (X MAX)	- + 7 mm
FLOW DENSITY IN THE GAP	9.680 GAUSS

*Thiele-Small parameters are obtained after applying a sinusoidal level of 50hz for a period of 30 minutes. A tolerance of + - 15% on the specified values is allowed.*

## PRODUCT DIMENSIONS

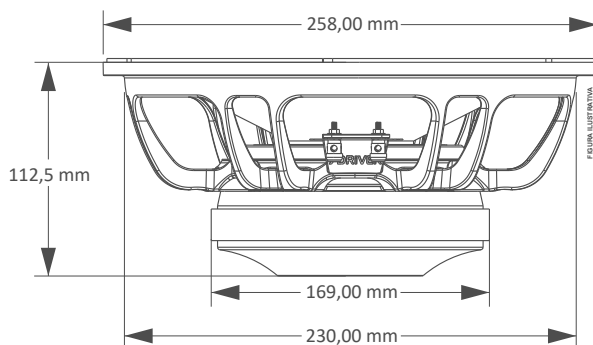

## MECHANICAL PARAMETERS

NOMINAL DIAMETER	10 inches
FERRITE MEASURES	169 x 24 mm
COIL DIAMETER	3 inches
COIL HEIGHT	18 mm
COIL WIRE MATERIAL	CCAW
COIL WIRE SECTION	Round
COIL SHAPE	Fiber
GAP HEIGHT	7,7 mm
HOUSING MATERIAL	Steel
FERRITE MATERIAL	Barium
WEIGHT	5,9 Kg
VOLUME OCCUPIED ON THE CABINET	2,1 Liters

## CABINETS SUGGESTION

MODEL	VOLUME	DUCTS	DUCTS	DUCTS	SYNTONY	(H.P.F)	ATTENUATION (ACTIVE)
	LITERS	QUANT.	DIAM.	DEPTH			
VENTED BOX	30	03	3"(POL)	115 mm	80 Hz	75 Hz	-24 dB/ Octave
	25	03	3"(POL)	102 mm	90 Hz	85 Hz	-24 dB/ Octave

SUGGESTIVE MEASURES

\*For professional lines, the use of a cotton or glass wool blanket is mandatory.

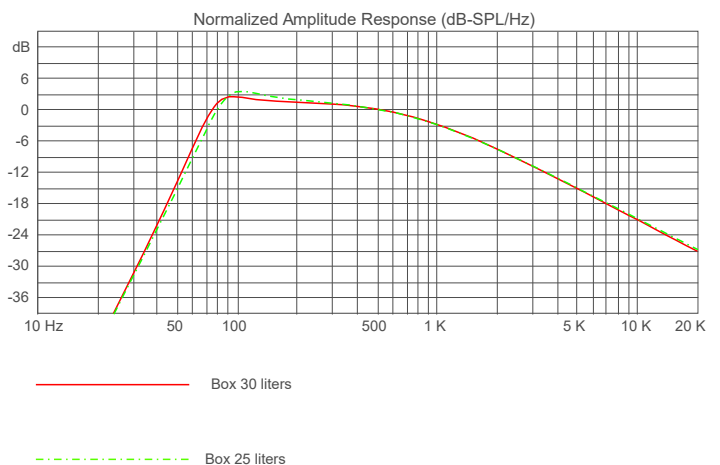

[www.taramps.com.br](http://www.taramps.com.br)

Rod. Julio Budisk SP 501 s/n, - Compl. KM 30-A/SP ZIP:19.180-000 Phone Number +55 (18) 3266-4050 National Registry(CNPJ): 23.372.795/0001-64

Note: Features, specifications and aesthetics are subject to change without notice.

## WARRANTY TERM

When all our products are produced, they undergo rigorous evaluations, in each construction process until they are packaged, however, if any type of abnormality is detected, when opening the package, it must be sent to one of our authorized service stations, or directly to the factory, if there is not an authorized technician in your region. **Each and every product must undergo a technical evaluation so that the defect is identified and proven.**

The product has a warranty of 15 (fifteen) months after the issuance of the invoice, with the legal warranty of 90 days, provided for in article 26, item II, of law No. 8078/90 (Brazilian consumer protection code).

### Warranty Conditions:

The product must be installed correctly, by a specialized professional, as well as respecting the product characteristics.

The customer **will NOT** have the warranty when:

- Exceed the period of 15 (fifteen) months.
- Damages incurred are caused by; transport or handling accident, or humidity.
- Defects caused by improper installation.
- Malfunctions in product parts (torn cone/dust cap, bent or broken speaker housing).
- Coils burned out by excessive power or extreme distortion conditions, causing heating above 240°.

### Warranty Coverage:

- Taramps guarantees its products against any defect in material or manufacturing process, provided that, at the discretion of its authorized technicians, it is found to be defective under normal conditions of use.
- **The PRODUCT must contain the original label, on which its serial number is inserted.**
- To use the warranty, the customer must present the invoice and the warranty term, both of which must contain the serial number on the product label.

### Transport

Only products that fall under the terms of warranty coverage will have their transportation expenses covered, otherwise, the expense will be at the customer's expense.

# WARRANTY CERTIFICATE

NAME: \_\_\_\_\_

ADDRESS: \_\_\_\_\_

CITY: \_\_\_\_\_ ZIP: \_\_\_\_\_

STATE: \_\_\_\_\_ PHONE: \_\_\_\_\_

DEALER: \_\_\_\_\_

ADDRESS: \_\_\_\_\_

CITY: \_\_\_\_\_ ZIP: \_\_\_\_\_

STATE: \_\_\_\_\_ PHONE: \_\_\_\_\_

INVOICE NUMBER