



# MH 380



The MH 380 model is designed to reproduce the mid-low and mid-high frequency ranges with great fidelity and clarity. Suitable for any type of sound system, whether 3-way car audio systems or professional use systems such as line arrays, monitors, cinemas, theaters, etc., providing clean and well-defined tones.

## ELECTRIC PARAMETERS

RMS POWER	380 W
MUSICAL PROGRAM POWER	760 W
NOMINAL IMPEDANCE	4 or 8 Ohms
RESISTANCE	3,0 / 5,2 ohms/VCC
NO (Efficiency reference)	1,613%
DIAPHRAGM MASS (MMD)	20,379 g
SENSITIVITY (@ 1W, 1m)-Free-Air	94,094 dB
TOTAL MASS (MMS)	22,081 g
BL PRODUCT	13.186 TM
MECHANICAL Q (Qms)	5,897
ELECTRIC Q (Qes)	0,303
TOTAL Q (Qts)	0,288
COMPLIANCE (CMS)	215,610u M/N
EQUIVALENT VOLUME (VAS)	13,008 L
FREQUENCY RESPONSE	70 to 7.000 Hz
RESONANCE FREQUENCY	73 Hz
Le @ 10 kHz (coil inductance at 10 kHz)	0,2804 mH
EFFECTIVE CONE AREA (SD)	0,0206 Sq.m
CONE EXCUNSION WITHOUT DISTORTION (X MAX)	- + 4,5 mm
FLOW DENSITY IN THE GAP	12.370 GAUSS

*Thiele-Small parameters are obtained after applying a sinusoidal level of 50hz for a period of 30 minutes. A tolerance of + - 15% on the specified values is allowed.*

## PRODUCT DIMENSIONS

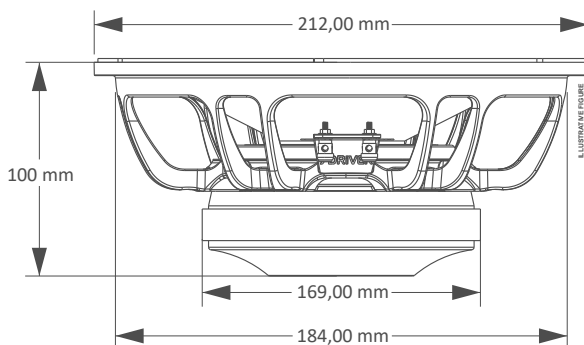

## MECHANICAL PARAMETERS

NOMINAL DIAMETER	8 Inches
FERRITE MEASURES	169 x 24 mm
COIL DIAMETER	3 Inches
COIL HEIGHT	13 mm
COIL WIRE MATERIAL	Aluminum
COIL WIRE SECTION	Flat
COIL SHAPE	Fiber
GAP HEIGHT	8 mm
HOUSING MATERIAL	Aluminum
FERRITE MATERIAL	Barium
WEIGHT	5,9 Kg
OCCUPIED VOLUME ON THE CABINET	1,5 Liters

## CABINETS SUGGESTION

MODEL	VOLUME	DUCTS	DUCTS	DUCTS	SYNTONY	(H.P.F)	ATTENUATION (ACTIVE)
	LITERS	QUANT.	DIAM.	DEPTH			
VENTED BOX	22	02	3"(POL)	105 mm	80 Hz	75 Hz	- 24 dB/ Octave
	16	02	3"(POL)	105 mm	100 Hz	95 Hz	- 24 dB/ Octave

SUGGESTIVE MEASURES

\*For professional lines, the use of a cotton or glass wool blanket is mandatory.

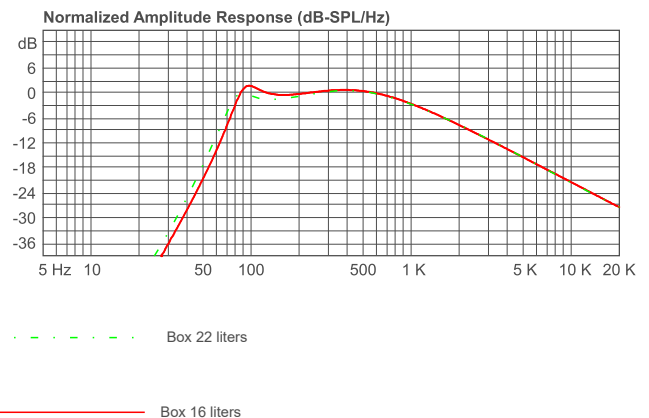

[www.taramps.com.br](http://www.taramps.com.br)

Rod. Julio Budisk SP 501 s/n, - Compl. KM 30-A /SP ZIP 19.180-000 Phone +55 (18) 3266-4050 CNPJ (National Registry): 23.372.795/0001-64  
NOTE: Features, specifications and aesthetics are subject to change without notice.

## WARRANTY TERM

When all our products are produced, they undergo rigorous evaluations, in each construction process until they are packaged, however, if any type of abnormality is detected, when opening the package, it must be sent to one of our authorized service stations, or directly to the factory, if there is not an authorized technician in your region. **Each and every product must undergo a technical evaluation so that the defect is identified and proven.**

The product has a warranty of 15 (fifteen) months after the issuance of the invoice, with the legal warranty of 90 days, provided for in article 26, item II, of law No. 8078/90 (Brazilian consumer protection code).

### Warranty Conditions:

The product must be installed correctly, by a specialized professional, as well as respecting the product characteristics.

The customer **will NOT** have the warranty when:

- Exceed the period of 15 (fifteen) months.
- Damages incurred are caused by; transport or handling accident, or humidity.
- Defects caused by improper installation.
- Malfunctions in product parts (torn cone/dust cap, bent or broken speaker housing).
- Coils burned out by excessive power or extreme distortion conditions, causing heating above 240°.

### Warranty Coverage:

- Taramps guarantees its products against any defect in material or manufacturing process, provided that, at the discretion of its authorized technicians, it is found to be defective under normal conditions of use.
- **The PRODUCT must contain the original label, on which its serial number is inserted.**
- To use the warranty, the customer must present the invoice and the warranty term, both of which must contain the serial number on the product label.

### Transport

Only products that fall under the terms of warranty coverage will have their transportation expenses covered, otherwise, the expense will be at the customer's expense.

# WARRANTY CERTIFICATE

NAME: \_\_\_\_\_

ADDRESS: \_\_\_\_\_

CITY: \_\_\_\_\_ ZIP: \_\_\_\_\_

STATE: \_\_\_\_\_ PHONE: \_\_\_\_\_

DEALER: \_\_\_\_\_

ADDRESS: \_\_\_\_\_

CITY: \_\_\_\_\_ ZIP: \_\_\_\_\_

STATE: \_\_\_\_\_ PHONE: \_\_\_\_\_

INVOICE NUMBER