



SL2K8



SL 2K8, a 15-inch loudspeaker specially developed to reproduce bass with high income and performance, providing your ears with an incredible sound sensation. The SL 2K8 has a unique mechanical composition, to offer much more with less wear and tear. Welcome to our sound world.

ELECTRIC PARAMETERS

RMS POWER	1.400 W
MUSICAL PROGRAM POWER	2.800 W
NOMINAL IMPEDANCE	4 or 8 Ohms
RESISTANCE	2,8 or 5,8 ohms/VCC
NO (EFFICIENCY REFERENCE)	1,912%
SENSITIVITY (@ 1W, 1 m)-Free-Air	94,834 dB
DIAPHRAGM MASS (MMD)	148,018 g
TOTAL MASS (MMS)	162,401 g
BL PRODUCT	19.004 TM
MECHANICAL Q (Qms)	11,166
ELECTRIC Q (Qes)	0,362
TOTAL Q (Qts)	0,351
COMPLIANCE (CMS)	79.883u M/N
EQUIVALENT VOLUME (VAS)	82.981 L
FREQUENCY RESPONSE	35Hz to 1.400Hz
RESONANCE FREQUENCY	44,187 Hz
Le @ 10 kHz (Coil inductance at 10 kHz)	0,522 mH
EFFECTIVE CONE AREA (SD)	0,0855 Sq.m
CONE EXCURSION WITHOUT DISTORTION (X MAX)	- + 12,2 mm
FLOW DENSITY IN THE GAP	9.300 GAUSS

Thiele-Small parameters are obtained after applying a sinusoidal level of 50 hz for a period of 30 minutes. A tolerance of + - 15% on the specified values is allowed.

MECHANICAL PARAMETERS

NOMINAL DIAMETER	15 Inches
FERRITE MEASURES	220 X 110 X 25mm
COIL DIAMETER	4 Inches
COIL HEIGHT	31 mm
COIL WIRE MATERIAL	Copper
COIL WIRE SECTION	Round
COIL SHAPE	Fiber
GAP HEIGHT	13,5 mm
HOUSING MATERIAL	Aluminum
FERRITE MATERIAL	Barium
WEIGHT	14 Kg
VOLUME OCCUPIED ON THE CABINET	6,0 Liters

CABINET SUGGESTIONS

MODEL	VOLUM	DUCT	DUCT	DUCT	TUNE	(H.P.F)	ATTENUATION
	LITERS	AUMONT	DIAMETER	DEPTH			(ACTIVE)
VENTED BOX	75	04	4"(Inches)	138 mm	65 Hz	63 Hz	- 24 dB/ 8º
	85	03	4"(Inches)	175 mm	55 Hz	50 Hz	- 24 dB/ 8º
	117	03	4"(Inches)	140 mm	48 Hz	45 Hz	- 24 dB/ 8º

Normalized Amplitude Response (dB-SPL/Hz)

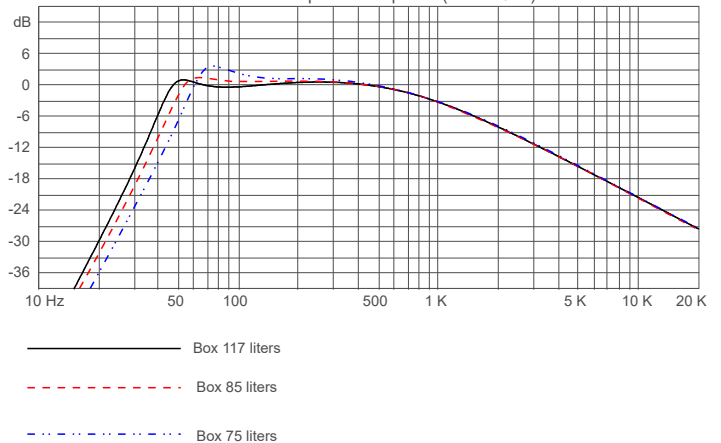

PRODUCT DIMENSIONS

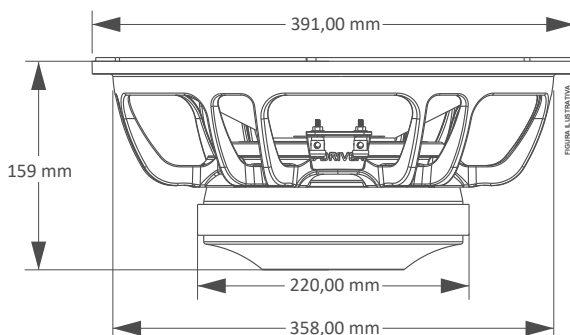

www.taramps.com.br

WARRANTY TERM

When all our products are produced, they undergo rigorous evaluations, in each construction process until they are packaged, however, if any type of abnormality is detected, when opening the package, it must be sent to one of our authorized service stations, or directly to the factory, if there is not an authorized technician in your region. **Each and every product must undergo a technical evaluation so that the defect is identified and proven.**

The product has a warranty of 15 (fifteen) months after the issuance of the invoice, with the legal warranty of 90 days, provided for in article 26, item II, of law No. 8078/90 (Brazilian consumer protection code).

Warranty Conditions:

The product must be installed correctly, by a specialized professional, as well as respecting the product characteristics.

The customer **will NOT** have the warranty when:

- Exceed the period of 15 (fifteen) months.
- Damages incurred are caused by; transport or handling accident, or humidity.
- Defects caused by improper installation.
- Malfunctions in product parts (torn cone/dust cap, bent or broken speaker housing).
- Coils burned out by excessive power or extreme distortion conditions, causing heating above 240°.

Warranty Coverage:

- Taramps guarantees its products against any defect in material or manufacturing process, provided that, at the discretion of its authorized technicians, it is found to be defective under normal conditions of use.
- **The PRODUCT must contain the original label, on which its serial number is inserted.**
- To use the warranty, the customer must present the invoice and the warranty term, both of which must contain the serial number on the product label.

Transport

Only products that fall under the terms of warranty coverage will have their transportation expenses covered, otherwise, the expense will be at the customer's expense.

WARRANTY CERTIFICATE

NAME: _____

ADDRESS: _____

CITY: _____ ZIP: _____

STATE: _____ PHONE: _____

DEALER: _____

ADDRESS: _____

CITY: _____ ZIP: _____

STATE: _____ PHONE: _____

INVOICE NUMBER