

# Product Manual

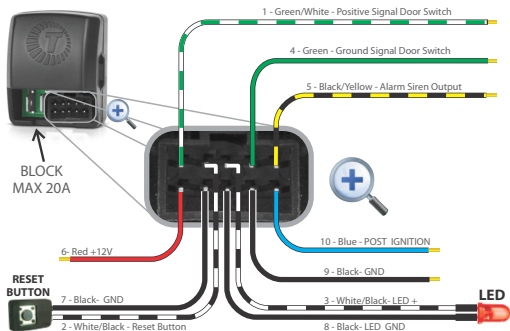

## BLOCK PART **G2**

## Installation Scheme



### Operation

#### Block Function:

- Activates when opening and closing the door with the ignition on and not pressing the RESET button.
- After 50 seconds, the LED flashes and the siren goes off if installed (not included), another 20 seconds the progressive block initiates. Definitive blockage occurs after another 30 seconds.
- To CANCEL the LOCKOUT, press the RESET button at any time, the LED will flash 1(once) to indicate the lockout cancellation..

#### VALET Function:

- Temporarily cancels the Lock function. It is used when leaving the vehicle in a parking lot, without the need to indicate the location of the Reset button (secret) to the valet.
- With the ignition off, hold the Reset button until the LED flashes 2 times (5 seconds). To cancel the valet function, turn on the ignition and press the Reset button for 1 second, The LED will flash 1x (once) confirming cancellation.

## Technical Features

Supply Voltage	9 a 15 Volts
Consumption	1 a 6 mA
Engine Lock	Max. 20A
Siren Output	Only Use Dedicated Siren

## Warranty terms

TARAMPS, located at Rua Abílio Daguano, 274 Res. Manoel Martins - Alfredo Marcondes - SP, ZIP 19.180-000, guarantees this product against design, manufacturing, assembly and/or joint and several defects due to design flaws that make it unsuitable or inappropriate for its intended use, for a period of 24 months from the date of purchase.

In the event of a defect within the warranty period, TARAMPS' liability is limited to repairing or replacing the device manufactured by it.

### **This warranty excludes:**

Products damaged by incorrect installation, water infiltration, tampering by unauthorized individuals;

Scratched or torn warranty seal;

Cases where the product is not used under regular conditions;

Defects caused by accessories, modifications or equipment attached to the product;

Natural wear components, such as batteries and others;

The product presents damage resulting from drops, impacts or the action of agents of nature (floods, lightning, etc.);

Costs of removal and reinstallation of the equipment, as well as its transport to the technical assistance post;

Damages of any type, resulting from problems with the product, as well as losses caused by discontinuation of use.

## Technical Support

Factory technical assistance department:

**Taramps Electronics** - Rua: Abílio Daguano, nº 274 - ZIP 19.180-000

Phone Number +55(18) 3266-4050 / 99749-3391

E-mail: [service@taramps.com.br](mailto:service@taramps.com.br)



A Taramps reserves the right to change the contents of this manual without prior notice or obligation to apply the modifications to previously produced units.



+55 18 3266-4050



0800 777 0990

Fabricado por / Manufactured by:  
TARAMPS ELECTRONICS LTDA  
CNPJ / TAX ID: 11.273.485/0001-03  
R. João Silvério, 121 • Res. Manoel Martins  
Alfredo Marcondes - SP  
Indústria Brasileira - Made in Brazil  
[www.taramps.com.br](http://www.taramps.com.br)